

A Novel Hysteresis Bandwidth (NHB) Calculation To Fix the Switching Frequency Employed In Active Power Filter

Hani Vahedi

Department of Electrical Engineering
Islamic Azad University, Sari Branch
Sari, Iran

hvahedi@ieee.org,

Abdolreza Sheikholeslami

Department of Electrical Engineering
Babol University of Technology
Babol, Iran

asheikh@nit.ac.ir

Mohammad Tavakoli Bina

Department of Electrical Engineering
K.N.Toosi University of Technology
Tehran, Iran

tavakoli@eetd.kntu.ac.ir

Abstract - Variable switching process is the main issue in practical implementation of fixed band hysteresis current controller in active power filters (APF) that increases the switching frequency and switching losses in power systems. Preventing this case, the Adaptive Hysteresis Current Control (AHCC) has been introduced and developed by many researchers. By this way, The Hysteresis Band (HB) will change adaptively by system parameters in order to control the switching speed and fix the switching frequency.

In this paper a revisory method for the hysteresis bandwidth calculation procedure is proposed that makes switching frequency invariable significantly. The APF Simulations using proposed method (NHB) in Matlab/Simulink environment has been done. Results including switching frequency and current source TDH have been given to prove the efficiency of this method.

Index Terms - Active Power Filter, Hysteresis Current Control, Instantaneous Power Theory, Power System Harmonic, Voltage Source Inverter (VSI).

I. INTRODUCTION

In recent years, shunt active power filters have being applied by many industries and researchers to remove the current harmonics caused by nonlinear loads [1-3]. An APF as can be seen in Figure 1 is a parallel power inverter with loads that can remove large amounts of current harmonics through the injection of reference current to the power system that contains harmonic components of the source current. Complete compensation occurs when the APF produces a same current as harmonic current with the same amplitude and opposite in sign.

Hysteresis current control is one of the most appropriate PWM switching methods to produce reference current in APFs [4]. Hysteresis current control has desirable characteristics such as high stability, fast and accurate dynamic behavior. On the other hand, conventional hysteresis method includes some undesirable results, such as variable switching frequency that causes audio noises, high switching losses and injection of high frequency current components to the source current that makes it difficult to design suitable filters to remove these high- frequency harmonics [5].

AHCC was presented to solve this problem [6-8]. According to this method, a variable band is defined for reference current in each phase so that the switching frequency remains constant. Since the bandwidth is changed every time the switching pattern becomes symmetrical and so switching

speed is limited to a fixed amount and switching frequency will be invariable and its range will be reduced.

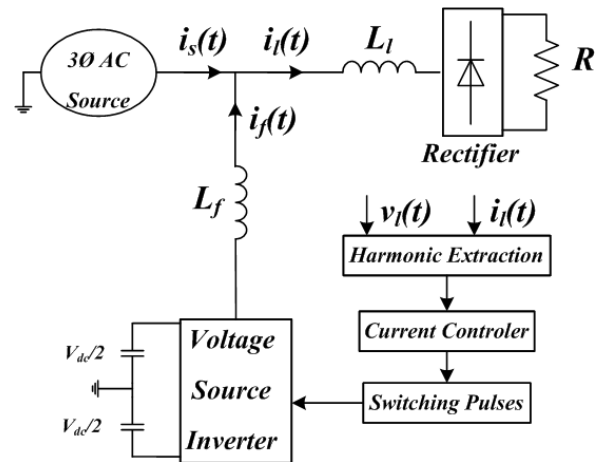

Fig. 1. Overview of APF connected to the power network

In this paper a new method (NHBC) has been suggested for calculating the variable bandwidth that has great effect on the switching frequency and reduces its range more than usual modes leads to lower switching losses and audio noises. Bandwidth, in the new formula will be slightly smaller but the switching frequency will be more constant and the source current THD is improved. In Section 2, the Instantaneous power theory is explained to extract harmonic components of load current, due to its effective performance. In section 3 the NHB method is presented and the necessary equations to calculate the bandwidth are given in this way. Then in Section 4, simulation of an APF in power network with nonlinear load in Matlab/Simulink environment has been done. The results of simulation that include instantaneous switching frequency and source current TDH show that the NHB has significant effect on reducing the switching frequency changes and source current TDH.

II. EXTRACTION OF THE COMPENSATION REFERENCE CURRENTS

One of the popular compensation reference current extraction methods is the instantaneous reactive power theory (p-q theory). Although there are some problems with this theory, it is well-established and simple in implementation. The p-q theory could be briefly reviewed as follow [9]:

Assume a three-phase load with the instantaneous voltages as $\mathbf{v}(t)=[v_a(t) \ v_b(t) \ v_c(t)]^t$ and the instantaneous currents as $\mathbf{i}_l(t)=[i_{la}(t) \ i_{lb}(t) \ i_{lc}(t)]^t$ (Fig. 1). Using (1), $\mathbf{v}(t)$ and $\mathbf{i}_l(t)$ can be converted to α - β coordination where \mathbf{C} is the matrix (2):

$$[v_{\alpha\beta}(t)]^t = \mathbf{C} [v_{abc}(t)]^t, [i_{\alpha\beta}(t)]^t = \mathbf{C} [i_{abc}(t)]^t \quad (1)$$

$$\mathbf{C} = \sqrt{\frac{2}{3}} \begin{bmatrix} \frac{1}{\sqrt{2}} & \frac{1}{\sqrt{2}} & \frac{1}{\sqrt{2}} \\ 1 & -\frac{1}{2} & -\frac{1}{2} \\ 0 & \frac{\sqrt{3}}{2} & -\frac{\sqrt{3}}{2} \end{bmatrix} \quad (2)$$

Let's assume that the zero sequence current ($i_{l0}(t)$) is null. Thus, the instantaneous active ($p(t)$) and reactive ($q(t)$) powers can be calculated as:

$$\begin{bmatrix} p(t) \\ q(t) \end{bmatrix} = \begin{bmatrix} v_{\alpha}(t) & v_{\beta}(t) \\ -v_{\beta}(t) & v_{\alpha}(t) \end{bmatrix} \begin{bmatrix} i_{l\alpha}(t) \\ i_{l\beta}(t) \end{bmatrix} \quad (3)$$

$p(t)$ and $q(t)$ can be decomposed to the average parts ($\bar{p}(t), \bar{q}(t)$) and the oscillating parts ($\tilde{p}(t), \tilde{q}(t)$). It is notable that $\bar{p}(t)$ is produced by the fundamental harmonic of the positive sequence component of the load current. Therefore, in order to compensate the harmonics and the instantaneous reactive power, compensation reference currents can be extracted as follow:

$$\begin{bmatrix} i_{f\alpha}^*(t) \\ i_{f\beta}^*(t) \end{bmatrix} = \begin{bmatrix} v_{\alpha}(t) & v_{\beta}(t) \\ -v_{\beta}(t) & v_{\alpha}(t) \end{bmatrix}^{-1} \begin{bmatrix} -\tilde{p}(t) \\ -q(t) \end{bmatrix} \quad (4)$$

$$[i_{fa}^*(t) \ i_{fb}^*(t) \ i_{fc}^*(t)]^t = \mathbf{C}^{-1} [0 \ i_{f\alpha}^*(t) \ i_{f\beta}^*(t)]^t \quad (5)$$

III. THE PROPOSED NHBC METHOD

The basic implementation of hysteresis current controller derives the switching signals by comparing the current error signal with a fixed hysteresis band (Fig. 2). In case the error signal touches the upper band, inverter voltage decreases to reduce the filter current and if the error signal violates the lower band, the inverter voltage increases to raise the filter current.

The hysteresis current control technique is the most suitable method for current control of Voltage Source Inverters (VSIs) in APFs due to its very fast response and good accuracy. On the other hand, the conventional hysteresis technique exhibits several undesirable features, such as uneven switching frequency that causes acoustic noise and difficulty in the designing input filters. The switching frequency of the hysteresis current control method depends on how fast the current changes from the upper limit to the lower limit of the hysteresis band, or vice versa [6, 8].

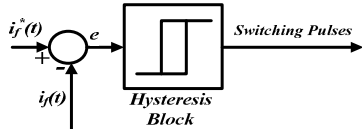

Fig. 2 hysteresis current control loop.

As above-mentioned, the crucial concern with the fixed band hysteresis current control is producing a varying modulation frequency of the power converter which, in turn, results in increasing the risk of resonance in power system. To

avoid this situation, adaptive hysteresis current controller methods with the variable hysteresis band have been recommended in literature [6, 7]. Hence, a variable hysteresis band is defined for each phase so that the switching frequency remains almost constant.

In circuit instances of power system, the current's path can be selected desirably. If the current path is opposite selected path, the circuit analysis results will differ only in signs that are negative and won't make a difference in their values. If we consider the current path in calculating HB, we will achieve the new formula (NHB). In this case, we consider the current path from the network to the inverter side as it is observed in figure 2. It should be mentioned that analyzing the circuit by choosing reverse path for the current, makes no different in result.

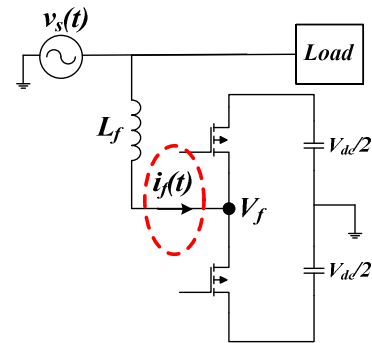

Figure 3: One phase from 3-phase VSI by reserved current assumption

The NHB formula can be calculated based on Fig. 1, also it can be achieved from Fig. 3 easier. According to Fig. 3, the following KVL equation can be easily achieved:

$$\frac{di_f(t)}{dt} = \frac{1}{L_f} (v_s(t) - V_f) \quad (6)$$

Where V_f is the inverter-side voltage and can be elaborated as below:

$$V_f = \begin{cases} \frac{V_{dc}}{2} & \text{the upper switch is ON} \\ -\frac{V_{dc}}{2} & \text{the lower switch is ON} \end{cases} \quad (7)$$

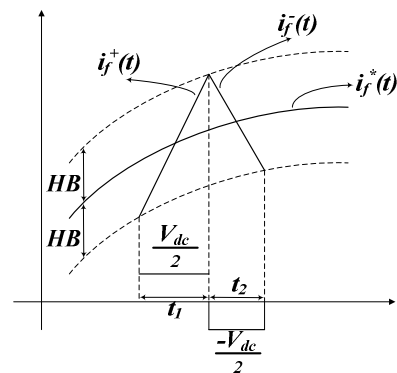

Fig. 4 The upper and lower bands of the reference compensation current.

Having paid attention to Fig. 4, the below relations can be obtained:

$$\frac{di_f^+(t)}{dt} = \frac{1}{L_f}(v_s(t) - V_f) \quad (8)$$

$$\frac{di_f^-(t)}{dt} = \frac{1}{L_f}(v_s(t) + V_f) \quad (9)$$

Where $i_f^+(t)$ and $i_f^-(t)$ are the rising current and the falling current, respectively. Furthermore, the following relations can be extracted:

$$\begin{cases} \frac{di_f^+(t)}{dt} \times t_1 - \frac{di_f^*(t)}{dt} \times t_1 = 2HB \\ \frac{di_f^-(t)}{dt} \times t_2 - \frac{di_f^*(t)}{dt} \times t_2 = -2HB \end{cases} \quad (10)$$

$$f = \frac{1}{t_1 + t_2} \quad (11)$$

Where t_1 and t_2 are switching intervals and f is the switching frequency.

By substituting (8), (9) and (11) in (10), the novel hysteresis bandwidth (NHB) can be derived as follow:

$$NHB = \frac{-V_{dc}}{8fL_f} + \frac{L_f}{2fV_{dc}} \left(v_s(t) - \frac{di_f^*(t)}{dt} \right)^2 \quad (12)$$

The adaptive HB should be derived instantaneously during each sample time to keep the switching frequency constant.

The conventional HB formula which is calculated with normal direction of the filter current is [6, 7]:

$$HB = \frac{V_{dc}}{8fL_f} - \frac{L_f}{2fV_{dc}} \left(v_s(t) + \frac{di_f^*(t)}{dt} \right)^2 \quad (13)$$

As it can be seen, the new formula for the bandwidth has certain differences with the present formula regarding to its initial terms. Proposed formula will result smaller band width, but reduces the frequency changes sensibly that will be proved by simulation in next section.

IV. SIMULATION RESULTS

In this part, simulation of an APF connected to the power network has been done by three methods of fixed band, AHCC and the proposed NHB with a balanced nonlinear load, including three phase rectifier and 20Ω resistor in Matlab/Simulink software.

TABLE 1
APF SIMULATION PARAMETERS

Supply Phase Voltage	200 V
Grid Frequency	60 Hz
Load Resistanc R_l	20 Ω
Inverter Side Inductance L_f	5 mH
Rectifier Side Inductance L_l	2 mH
APF dc-link Voltage V_{dc}	500 V
Fixed Hysteresis Bandwidth	0.67 A

Then the simulation results including switching frequency and source, load and filter currents are given below. In Fig. 5, load, filter and source currents can be seen for all three simulations. As this figure implies, the first column shows the fixed band results, the second column represents the conventional AHCC and the third column is related to the proposed NHB method. The top, middle and bottom rows show the load current, filter current and source current respectively.

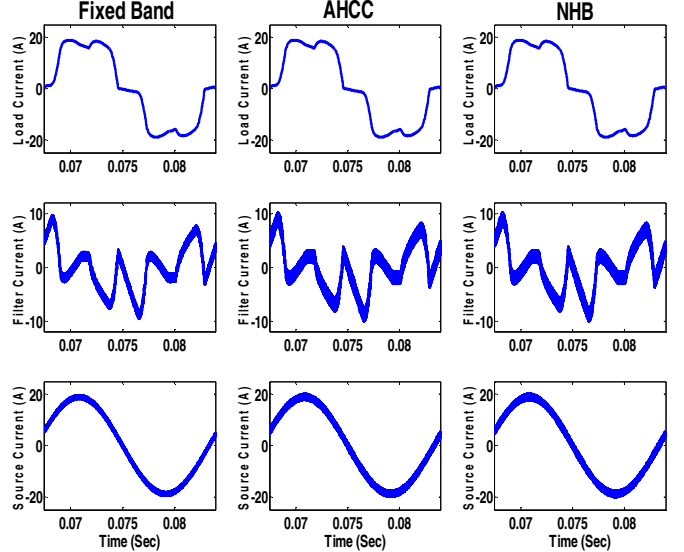

Fig. 5 Load, filter and source currents in three switching cases

Table 2 shows the load and source current RMS value that shows load current supplied properly by the source and filter.

TABLE 2
RMS VALUE OF LOAD AND SOURCE CURRENTS

	Source Current RMS (A)			Load Current RMS (A)		
	Phase a	Phase b	Phase c	Phase a	Phase b	Phase c
Fixed-band	13.40	13.40	13.39	13.86	13.86	13.86
AHCC	13.43	13.44	13.44	13.86	13.86	13.86
NHB	13.44	13.43	13.44	13.86	13.86	13.86

The THD% values of the source and load currents have been shown in Table 3. These numerical results show the appropriate performance of the proposed method.

TABLE 3
THD% VALUE OF LOAD AND SOURCE CURRENTS

	Source Current THD%			Load Current THD%		
	Phase a	Phase b	Phase c	Phase a	Phase b	Phase c
Fixed-band	3.01	2.72	2.38	22.01	22.01	22.01
AHCC	3.50	3.42	3.28	21.96	21.99	22.01
NHB	3.18	3.45	3.96	21.96	21.99	22.01

Important issue in switching with hysteresis method is its switching frequency changes. Fig. 6 shows instantaneous switching frequency for all three methods in this survey. Maximum and average and minimum numerical values of the switching frequency can be seen in Table 4.

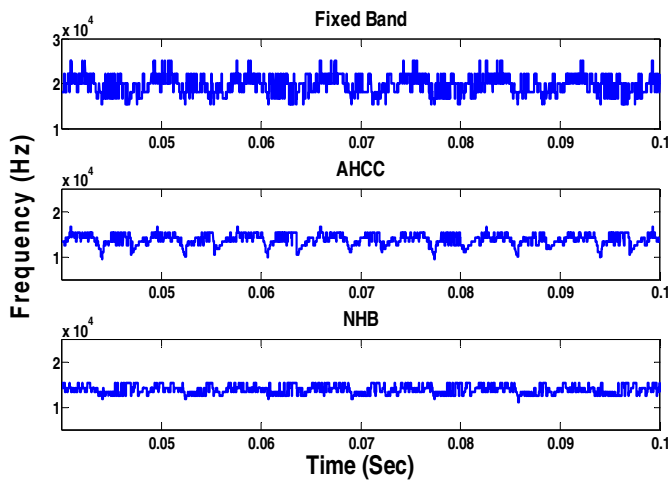

Fig. 6 Instantaneous switching frequency for 3 switching methods

TABLE 4
NUMERICAL SWITCHING FREQUENCY RESULTS FOR 3 SWITCHING METHODS

	SwitchingFrequency (KHz)		
	Min.	Average	Max.
Fixed-band	15.38	19.70	25.00
AHCC	9.52	13.72	16.66
NHB	11.11	13.85	15.38

Figure 6 and Table 4 indicate that in fixed band method, switching frequency increases and its variation is also higher. By definition of AHCC method, switching frequency and its range has been significantly reduced and the simulation continues with the proposed NHB method, the switching frequency range is limited to a smaller one than the two other cases.

As noted, changing in switching frequency not only causes audio noise and increases the switching losses but also injects high frequency current components to the source current. Therefore, by stabilizing switching frequency we can eliminate large amounts of current harmonics in high frequency.

The results of the proposed method including switching frequency and source current THD indicates suitable performance of the NHB formula in producing HB leads to switching pulses and making reference current, while reducing the source current THD optimally, switching frequency stabilization is done.

IV. CONCLUSION

Many studies have been performed to fix the switching frequency in hysteresis current control method using adaptive HB. This paper shows an efficient attempt in introducing a new formula for HB calculation (NHB) that produces more appropriate bandwidth leads to more smooth switching and more constant switching frequency. The simulations results for three switching methods prove the fact that the NHB formula introduces superior results in calculating the proper hysteresis bandwidth results o fix the switching frequency and solve the related problems like switching losses and audio noises.

REFERENCES

- [1] Bhim Singh, Jitendra Solanki, "An Implementation of an Adaptive Control Algorithm for a Three-Phase Shunt Active Filter", IEEE Transaction, 2009, Vol. 56, Iss. 8, pp. 2811-2820.
- [2] O. Vodyakho, T. Kim, "Shunt active filter based on three-level inverter for three-phase four-wire systems", IET Power Electronics, 2009, Vol. 2, Iss. 3, pp. 216-226.
- [3] Oleg Vodyakho, Chris C. Mi, "Three-Level Inverter-Based Shunt Active Power Filter in Three-Phase Three-Wire and Four-Wire Systems", IEEE Transaction, 2009, Vol. 24, Iss. 5, pp. 1350-1363.
- [4] Marian P. Kazmierkowski, Ramu Krishnan, Frede Blaabjerg, "Control in power electronics", Academic Press, 2002.
- [5] M. Tavakoli Bina, E. Pashajavid, "An efficient procedure to design passive LCL-filters for active power filters", Elsevier Journal Electric Power Systems Research, 2009, Vol. 79, Iss. 4, pp. 606-614.
- [6] B.K.Bose, "An Adaptive Hysteresis Band Current Control Technique of a Voltage Feed PWM Inverter for Machine Drive System", IEEE Trans. On Ind. Elec., 1990, pp. 402- 406
- [7] Hani Vahedi, Abdolreza Sheikholeslami, "Variable hysteresis current control applied in a shunt active filter with constant switching frequency", IEEE Conf. on Power Quality, PQC, 2010, pp.1-5
- [8] Hani Vahedi, Abdolreza Sheikholeslami, "The Source-Side Inductance Based Adaptive Hysteresis Band Current Control to be Employed in Active Power Filters", International Review on Modeling and Simulation Journal, Vol. 3, No. 5, October 2010, pp. 840-845.
- [9] Wenjin Dai, Yongtao DaiTingjian Zhong, "A New Method for Harmonic and Reactive Power Compensation", IEEE Int. Conf. on Industrial Technology, ICIT, 2008, pp.1-5.