

A Decomposition Procedure to Linearize the Non-affine State Space Average Model of STATCOM

M. Moradpour

K. N. Toosi University of
Technology
Tehran, Iran

milad.moradpour@ee.kntu.ac.ir

M. Tavakoli Bina

K. N. Toosi University of
Technology
Tehran, Iran

tavakoli@kntu.ac.ir

A. Khaki Sedigh

K. N. Toosi University of
Technology
Tehran, Iran

sedigh@kntu.ac.ir

M. Ayati

K. N. Toosi University of
Technology
Tehran, Iran

moosa_ayati@ee.kntu.ac.ir

Abstract—Various studies have been devoted to modulation and control of power electronic systems. Modeling of such a system is often required for control purposes. One modeling approach is the standard state space average model (SSSAM), which considers switching behaviors of the converters. The developed SSSAM of the static compensators (STATCOM) describes a non-affine model that is hardly controllable. A decomposition procedure has been proposed in this paper to make this non-affine SSSAM like an affine model. First, a non-affine SSSAM is derived that includes an interconnected STATCOM to an equivalent Thevenin model of the network along with the load. Then, the proposed decomposition procedure is applied to the non-affine SSSAM, where the resultant affine SSSAM is simulated. Simulations are presented for both the non-affine and the proposed affine model, showing the performance of the proposed procedure.

Keywords—Power electronic systems; state space average model; non-affine systems; STATCOM

I. INTRODUCTION

In order to achieve acceptable performance in control of power electronic systems, precise mathematical models are required. Meanwhile, power electronic systems have discontinuous switching behaviors, modeling these behaviors is complicated due to non-linear time-varying characteristics. The majority of researchers prefer avoiding modeling of switching dynamics by seeking alternative approaches such as dq-models [1], and soft computing based models [2], or developing modulation methods instead of using a regular controller [3].

SSSAM is a well-known technique for modeling power electronic systems which considers the switching behaviors of power electronic devices [4]. While most of the control methods are applied to the affine systems, the SSSAM provides a non-affine system.

This paper proposes a decomposition procedure for the SSSAM of power electronic systems which employs Taylor series expansion to achieve an affine linear time-varying standard state space model. It is noticeable that the resultant affine model still considers the switching function as the control input of the proposed SSSAM. Here non-affine systems with limit cycle especially STATCOM [5], are investigated in order to verify the validity of the proposed decomposition procedure. In fact, it is shown that the non-affine SSSAM of the studied STATCOM could be modified to an affine linear time-varying SSSAM using the suggested decomposition

procedure. Therefore, using this model a wider range of state space controllers such as pole placement method, optimal control, adaptive control, robust control, etc. could be applied to the power electronic systems with limit cycle.

II. METHODOLOGICAL PROCEDURE

A. Standard State Space Averaging Model (SSSAM)

SSSAM was established by Middlebrook and Cuk [6]. This method was introduced to manage a continuous averaged model out of the exact discontinuous switch-mode state space system [7].

The SSSAM of power electronic systems has been derived in [4]. Assume a power electronic device is toggling between r circuit topologies, spending a fraction of switching period in each circuit topology. $x(t)_{p \times 1}$ be the state vector, d_j be the fraction of the period in which the j th topology is active ($d_1 + d_2 + \dots + d_r = 1$) and T_s is the switching period.

$$\dot{x}(t) = A_m x(t) + B_m E, \text{ where} \quad (1)$$

$$A_m = \sum_{j=1}^r d_j A_j, B_m = \sum_{j=1}^r d_j B_j$$

Where A_j and B_j are the system matrices for the j th topology, and $E_{q \times 1}$ is the independent sources vector which is considered as a $(d(t))$ disturbance in the rest of the paper. Noting that A_j and B_j depend on the switching states. By defining r discontinuous switching functions for r available independent switching states as follows:

$$S_i(t) = \{-1, 1\}, i = \{1, 2, \dots, r\} \quad (2)$$

The value of each switching function is either -1 or 1 when the i th switching state goes either off or on, respectively. Considering $A_m = F(S(t))$ and $B_m = G(S(t))$,

$$S(t) = [S_1(t) S_2(t) \dots S_s(t)], G(S(t)) = \begin{bmatrix} G_{11}(S(t)) \\ \vdots \\ G_{1q}(S(t)) \end{bmatrix}, \quad (3)$$

$$F(S(t)) = \begin{bmatrix} F_{11}(S(t)) & \dots & F_{1p}(S(t)) \\ F_{21}(S(t)) & \dots & F_{2p}(S(t)) \\ \vdots & & \vdots \\ F_{p1}(S(t)) & \dots & F_{pp}(S(t)) \end{bmatrix}$$

Where f_{ij} and g_{ij} are scalar functions of $S(t)$. Then, (1) can be rewritten as:

$$\dot{x}(t) = F(S(t))x(t) + G(S(t))d(t) \quad (4)$$

B. Application to STATCOM

In [5], a SSSAM is developed for STATCOM when the grid coupling point (v_n) introduces no internal impedance, i.e. showing three independent sources, Fig. 1. The converter voltage is synthesized using a PWM switching method, producing a sinusoidal fundamental waveform (v_o) having the phase angle difference α with respect to the transformer coupling voltage (v_n). α is the bounded input of system or control signal of the physical system, i.e. the static compensator or STATCOM.

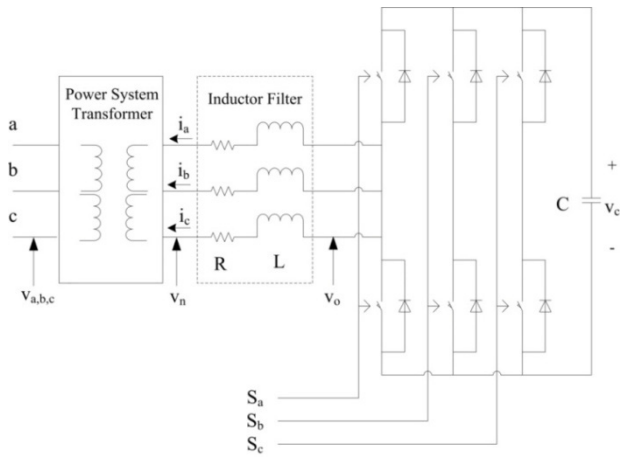

Fig. 1 Three-phase circuit of STATCOM

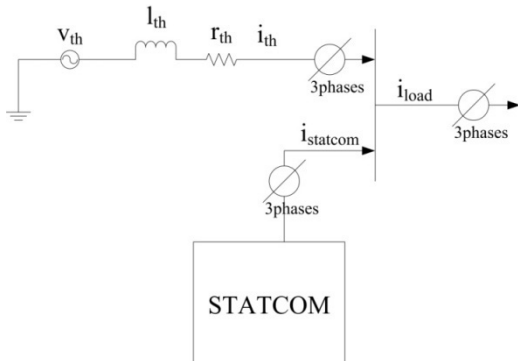

Fig. 2 STATCOM, load and thevenin model of network

An internal impedance (r_{th} and L_{th}) is considered for the grid coupling point in order to have a more practical model as shown in Fig. 2.

Hence, the average model in [5] is modified to get the realistic state space model as (5).

$$\dot{x}(t) = \begin{pmatrix} A_r + A_a(2S_a(t) - 1) + A_b(2S_b(t) - 1) \\ + A_c(2S_c(t) - 1) \end{pmatrix} x(t) + d(t)$$

$$\text{Where } x(t) = \begin{bmatrix} i_a(t) \\ i_b(t) \\ v_c(t) \end{bmatrix},$$

$$\begin{cases} S_a(t) = \frac{1}{2} \left(1 + m \frac{\sin(\frac{\pi}{M})}{(\frac{\pi}{M})} \sin(\omega t - \frac{\pi}{M} + \alpha) \right) \\ S_b(t) = \frac{1}{2} \left(1 + m \frac{\sin(\frac{\pi}{M})}{(\frac{\pi}{M})} \sin(\omega t - \frac{\pi}{M} + \alpha + \frac{2\pi}{3}) \right), u(t) = \alpha, \\ S_c(t) = \frac{1}{2} \left(1 + m \frac{\sin(\frac{\pi}{M})}{(\frac{\pi}{M})} \sin(\omega t - \frac{\pi}{M} + \alpha - \frac{2\pi}{3}) \right) \end{cases}$$

$$\begin{cases} A_r = \begin{bmatrix} \frac{R - r_{th}}{L + l_{th}} & 0 & 0 \\ 0 & -\frac{R - r_{th}}{L + l_{th}} & 0 \\ 0 & 0 & 0 \end{bmatrix}, \\ A_a = \begin{bmatrix} \frac{r_{th}}{L + l_{th}} & 0 & \frac{1}{3(L + l_{th})} \\ 0 & \frac{r_{th}}{L + l_{th}} & -\frac{1}{6(L + l_{th})} \\ -\frac{1}{2C} & 0 & 0 \end{bmatrix}, \\ A_b = \begin{bmatrix} \frac{r_{th}}{L + l_{th}} & 0 & -\frac{1}{6(L + l_{th})} \\ 0 & \frac{r_{th}}{L + l_{th}} & \frac{1}{3(L + l_{th})} \\ 0 & -\frac{1}{2C} & 0 \end{bmatrix}, \\ A_c = \begin{bmatrix} \frac{r_{th}}{L + l_{th}} & 0 & -\frac{1}{6(L + l_{th})} \\ 0 & \frac{r_{th}}{L + l_{th}} & -\frac{1}{6(L + l_{th})} \\ \frac{1}{2C} & \frac{1}{2C} & 0 \end{bmatrix}, \\ d(t) = \begin{bmatrix} -\frac{2}{3(L + l_{th})} & \frac{1}{3(L + l_{th})} & \frac{1}{3(L + l_{th})} \\ \frac{1}{3(L + l_{th})} & -\frac{2}{3(L + l_{th})} & \frac{1}{3(L + l_{th})} \\ 0 & 0 & 0 \end{bmatrix} \\ \times \left(v_{th,3\phi} - r_{th} i_{load,3\phi} - l_{th} \frac{di_{load,3\phi}}{dt} \right) \end{cases} \quad (5)$$

Where ω is the network frequency, $m \in [0, 1]$ is the modulation index and M is the ratio indicating the switching frequency over the network frequency. (5) is non-affine time-varying SSSAM of STATCOM. Because most control methods are usefully applicable to affine systems, here a decomposition procedure is proposed to make (5) an affine system. Simulations show that (5) has a limit cycle as shown in Fig. 3.

Consider the STATCOM model (6) is expanded about the limit cycle (7).

$$\dot{x}(t) = f(x(t), u(t), d(t)) = F(u(t))x(t) + G(u(t))d(t) \quad (6)$$

$$\dot{x}_0(t) = f_0 = f(x_0(t), u_0(t), d(t)), t \geq t_l \quad (7)$$

t_l is the time that $x(t)$ enters into the limit cycle. Note that $x_0(t)$ in this case can be defined as $x_0(t) = x(t), t \geq t_l$. Therefore, the Taylor series expansion of f (neglecting the second order and higher terms) is:

$$\begin{aligned} \dot{x}(t) &= \Delta \dot{x}(t) + \dot{x}_0(t) \\ &= f_0 + \left. \frac{\partial f}{\partial x} \right|_{x_0, u_0} (x(t) - x_0(t)) + \left. \frac{\partial f}{\partial u} \right|_{x_0, u_0} (u(t) - u_0(t)) \end{aligned} \quad (8)$$

In (8), f_0 and $\dot{x}_0(t)$ cannot be assumed equal for $\forall t$; instead $f_0 = F(u_0(t))x_0(t) + G(u_0(t))d(t)$ can be simplified with $\left. \frac{\partial f}{\partial x} \right|_{x_0, u_0} x_0(t) = F(u_0(t))x_0(t)$, resulting in (9).

$$\dot{x}(t) = A_{linear} x(t) + B_{linear} u(t) + D(t) \text{ where}$$

$$A_{linear} = \left. \frac{\partial f}{\partial x} \right|_{x_0, u_0} = F(u_0(t)),$$

$$B_{linear} = \left. \frac{\partial f}{\partial u} \right|_{x_0, u_0} = \left. \frac{\partial F}{\partial u} \right|_{u_0} x_0(t) + \left. \frac{\partial G}{\partial u} \right|_{u_0} d(t), \quad (9)$$

$$D(t) = -\left. \frac{\partial f}{\partial u} \right|_{x_0, u_0} u_0(t) + G(u_0(t))d(t)$$

Hence (5) is modified to get the following affine SSSAM (10) for STATCOM.

C. Closed Loop Control Of Linearized Model

The affine SSSAM of STATCOM which was described by (10) is a linear, time-varying, state space model. A control algorithm for time-varying system should be used to design a closed-loop system like Fig. 3. In the closed-loop system, the controller will be designed based on the affine model and will be applied to the plant or non-affine model.

The input consists of two parts; reference input and controller input. Summary of reference and controller input should be confined. The maximum and minimum boundary of input, defined due to the α_0 .

$$\dot{x}(t) = A_{linear} x(t) + B_{linear} u(t) + D(t), \text{ Where}$$

$$A_{linear} = F(S_0(t)) = F(S(t))|_{\alpha=\alpha_0}, \quad u_0 = \alpha_0$$

$$B_{linear} = \left. \frac{\partial f}{\partial u} \right|_{x_0, u_0} = \left. \frac{\partial F}{\partial u} \right|_{u_0} x_0(t) = \begin{bmatrix} b_{l11} & b_{l12} & b_{l13} \\ b_{l21} & b_{l22} & b_{l23} \\ b_{l31} & b_{l32} & b_{l33} \end{bmatrix} x_0(t) \quad (10)$$

$$b_{l11} = \left[\begin{array}{c} \frac{r_{th} \cos\left(\frac{\pi}{2} + u_0 + 100\pi t\right)}{L + l_{th}} + \frac{r_{th} \cos\left(u_0 - \frac{\pi}{6} + 100\pi t\right)}{L + l_{th}} \\ + \frac{r_{th} \cos\left(\frac{7\pi}{6} + u_0 + 100\pi t\right)}{L + l_{th}} \end{array} \right]$$

$$b_{l12} = [0],$$

$$b_{l13} = \left[\begin{array}{c} \frac{\cos\left(\frac{\pi}{2} + u_0 + 100\pi t\right)}{3(L + l_{th})} - \frac{\cos\left(u_0 - \frac{\pi}{6} + 100\pi t\right)}{6(L + l_{th})} \\ - \frac{\cos\left(u_0 + \frac{7\pi}{6} + 100\pi t\right)}{6(L + l_{th})} \end{array} \right]$$

$$b_{l21} = [0],$$

$$b_{l22} = \left[\begin{array}{c} \frac{r_{th} \cos\left(\frac{\pi}{2} + u_0 + 100\pi t\right)}{L + l_{th}} + \frac{r_{th} \cos\left(u_0 - \frac{\pi}{6} + 100\pi t\right)}{L + l_{th}} \\ + \frac{r_{th} \cos\left(u_0 + \frac{7\pi}{6} + 100\pi t\right)}{L + l_{th}} \end{array} \right]$$

$$b_{l23} = \left[\begin{array}{c} \frac{\cos\left(u_0 - \frac{\pi}{6} + 100\pi t\right)}{3(L + l_{th})} - \frac{\cos\left(\frac{\pi}{2} + u_0 + 100\pi t\right)}{6(L + l_{th})} \\ - \frac{\cos\left(\frac{7\pi}{6} + u_0 + 100\pi t\right)}{6(L + l_{th})} \end{array} \right]$$

$$b_{l31} = \left[\frac{\cos\left(\frac{7\pi}{6} + u_0 + 100\pi t\right)}{2C} - \frac{\cos\left(\frac{\pi}{2} + u_0 + 100\pi t\right)}{2C} \right]$$

$$b_{l32} = \left[\frac{\cos\left(\frac{7\pi}{6} + u_0 + 100\pi t\right)}{2C} - \frac{\cos\left(u_0 - \frac{\pi}{6} + 100\pi t\right)}{2C} \right]$$

$$b_{l33} = [0],$$

$$D(t) = -\left. \frac{\partial f}{\partial u} \right|_{x_0, u_0} u_0(t) + d(t)$$

The equation of state variables (at this case, (10)) is used in control algorithms for regulation purposes. For tracking purpose, an output equation of system is needed. Output of STATCOM will be defined due to the tracking purposes such as bus voltage, injective reactive power, output current of inverter or etc. Here bus voltage output equation as an example can be derived as below:

Writing KVL and KCL circuit equation in Fig. 2 leads to:

$$v_{a,b,c} = \begin{pmatrix} r_{th} \begin{bmatrix} x_1 \\ x_2 \\ -(x_1 + x_2) \end{bmatrix} + l_{th} \begin{bmatrix} \dot{x}_1 \\ \dot{x}_2 \\ -(\dot{x}_1 + \dot{x}_2) \end{bmatrix} \\ \left(v_{v_{th,3\phi}} - \left(r_{th} + l_{th} \frac{d}{dt} \right) i_{load,3\phi} \right) \end{pmatrix} \quad (11)$$

In (11), state vector can be written as (12):

$$\begin{bmatrix} x_1 \\ x_2 \\ -(x_1 + x_2) \end{bmatrix} = \begin{bmatrix} 1 & 0 & 0 \\ 0 & 1 & 0 \\ -1 & -1 & 0 \end{bmatrix} \begin{bmatrix} x_1 \\ x_2 \\ x_3 \end{bmatrix}, \quad (12)$$

$$\begin{bmatrix} \dot{x}_1 \\ \dot{x}_2 \\ -(\dot{x}_1 + \dot{x}_2) \end{bmatrix} = \begin{bmatrix} 1 & 0 & 0 \\ 0 & 1 & 0 \\ -1 & -1 & 0 \end{bmatrix} \begin{bmatrix} \dot{x}_1 \\ \dot{x}_2 \\ \dot{x}_3 \end{bmatrix}$$

By replacing (12) into (11) and simplify the answer; the output equation is:

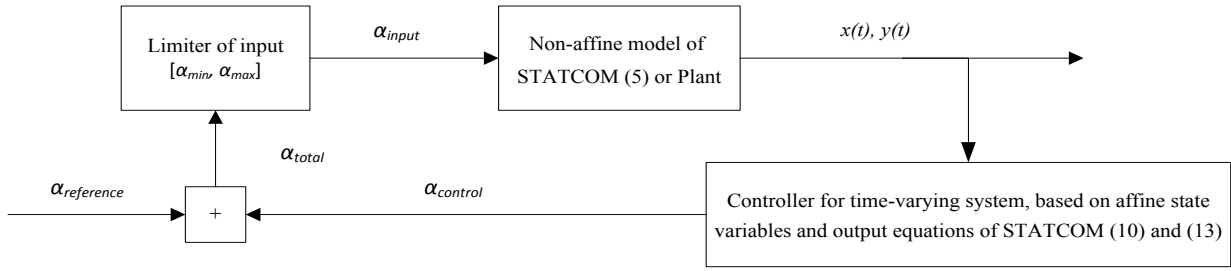

Fig. 3 Block diagram of closed-loop system of STATCOM

$$y(t) = v_{a,b,c} = C(t, u)x(t) + d_v(t),$$

$$C(t, u) = r_{th} \begin{bmatrix} 1 & 0 & 0 \\ 0 & 1 & 0 \\ -1 & -1 & 0 \end{bmatrix} + l_{th} \begin{bmatrix} 1 & 0 & 0 \\ 0 & 1 & 0 \\ -1 & -1 & 0 \end{bmatrix} \\ \times (I - B_{prime} l_{th})^{-1} (A + B_{prime} r_{th}),$$

$$d_v(t) = l_{th} \begin{bmatrix} 1 & 0 & 0 \\ 0 & 1 & 0 \\ -1 & -1 & 0 \end{bmatrix} (I - B_{prime} l_{th})^{-1} d_{prime} \\ + \left(v_{v_{th,3\phi}} - \left(r_{th} + l_{th} \frac{d}{dt} \right) i_{load,3\phi} \right), \text{ where}$$

$$A = (A_r + A_a(2S_a(t) - 1) + A_b(2S_b(t) - 1) + A_c(2S_c(t) - 1)), \quad (13)$$

$$B_{prime} = B - \begin{bmatrix} B(1,3) & B(1,3) & B(1,3) \\ B(2,3) & B(2,3) & B(2,3) \\ B(3,3) & B(3,3) & B(3,3) \end{bmatrix},$$

$$B = \begin{bmatrix} -2 & 1 & 1 \\ 3L & 3L & 3L \\ 1 & -2 & 1 \\ 3L & 3L & 3L \\ 0 & 0 & 0 \end{bmatrix},$$

$$d_{prime} = B \left(v_{v_{th,3\phi}} - \left(r_{th} + l_{th} \frac{d}{dt} \right) i_{load,3\phi} \right)$$

III. SIMULATIONS AND DISCUSSIONS

Various simulations were arranged for STATCOM using MATLAB, considering both non-affine and the proposed affine models described by (5) and (10), respectively.

A. Examination of the limit cycle for the non-affine model of (5)

Simulation of (5) shows that states are sinusoidal with constant amplitude. Both $i_a(t)$ and $i_b(t)$ have identical frequencies to that of the grid network, and the DC-link $V_c(t)$ has a dominant oscillations twice the frequency of the network.

Sinusoidal state variables can be a limit cycle for the system in practice, if the amplitudes of the state variables vary with change of the input, remains unchanged when initial state changes.

The amplitudes of sinusoidal states remain constant for different initial values of the state variables like simulation in Fig. 4 (b). Moreover varying the input would change the amplitudes of sinusoidal states like simulations in Fig. 4 (c) that introduce the limit cycle.

B. The decomposed affine model of (10)

State variables of STATCOM are sinusoidal waveforms in steady state, resulting in a limit cycle. Thus, both the non-affine model (5) and the affine model (10) have limit cycle. It is necessary to have α_0 when simulating (10). Also, different α_0 can be selected from $\alpha \in [-1.5, 1.5]$ ([5]) as below:

$$\alpha_0 \in \{-1.5, -1.0, -0.5, 0.0, 0.5, 1.0, 1.5\} \quad (14)$$

Then, for every $\alpha_{input} \in [-1.5, 1.5]$, the closest α_0 is selected from (14).

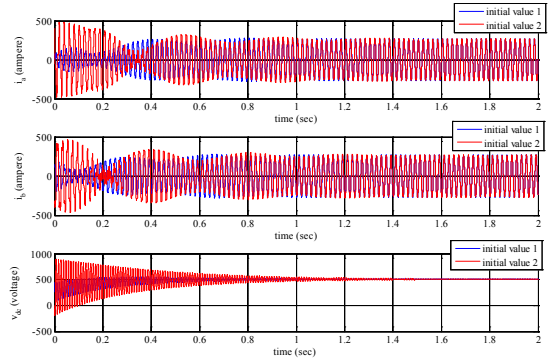

(a) Time plot and

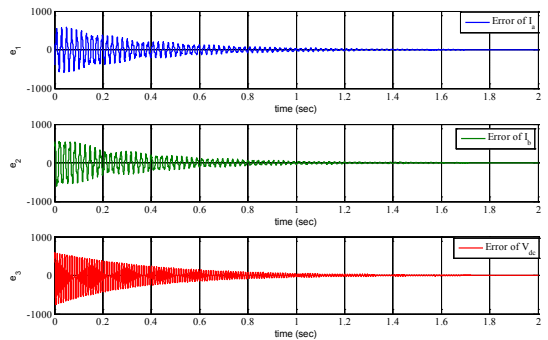
 (b) Error time plot ($e_i = x_{1i} - x_{2i}$, $i = 1, 2, 3$) for identical inputs ($\alpha = -0.3$) and different initial values ($x_{initial,1} = [0 \ 147 \ 440]^T$ and $x_{initial,2} = [400 \ -400 \ 0]^T$)

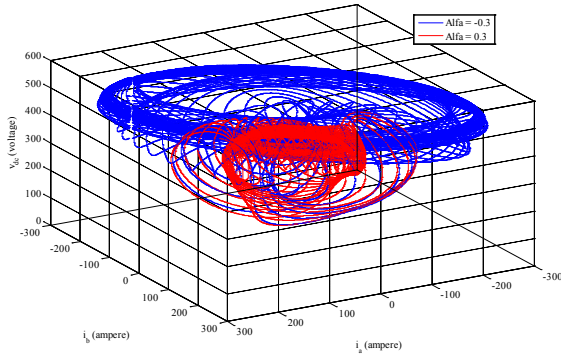

(c) Phase plane plot for identical initial values ($x_{initial} = [0 \ 147 \ 440]^T$) and different inputs ($\alpha_1 = -0.3$ and $\alpha_2 = 0.3$)

Fig. 4: States of non-affine system

For example, when $\alpha_{input} = 0.3$, then $\alpha_0 = 0.5$ is chosen. In fact, if $\alpha = 0.5$ is applied to (5), the limit cycle in steady state is:

$$x(t) = \begin{bmatrix} 11 \sin(50t) \\ 11 \sin(50t + \pi/3) \\ 325 + 2 \sin(100t) \end{bmatrix} \quad (15)$$

Here the simulation of (10) is carried out for $\alpha_{input} = 0.3$ and $\alpha_0 = 0.5$.

Fig. 5 shows the modeling error and time response of (5) and (10), with identical input and initial values.

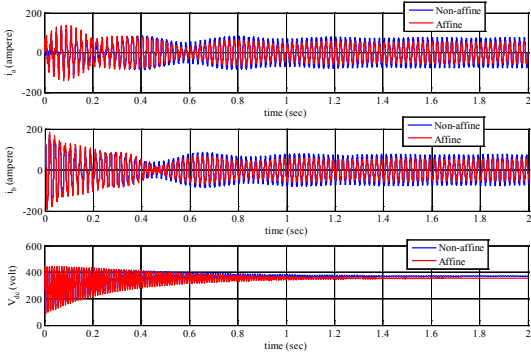

(a) Time plot

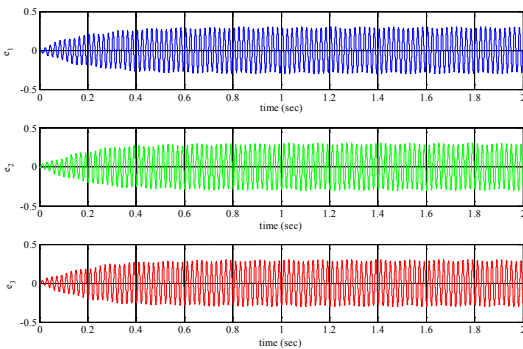

(b) Relative error time plot

$$(e_i = (x_{non-affine,i} - x_{affine,i}) / x_{non-affine,i}, i = 1,2,3)$$

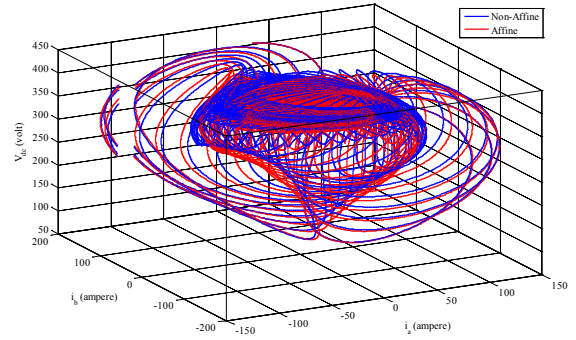

(c) Phase plane plot

Fig. 5: States of non-affine and affine system. $x_{initial} = [0 \ 147 \ 440]^T$, $\alpha = 0.3$, and $\alpha_0 = 0.5$

Also to compare the non-affine simulations with those of the affine system, the root mean squared error (RMSE) is considered as follows:

$$RMSE = [RMSE_1 \ RMSE_2 \ RMSE_3]^T, \text{ Where}$$

$$RMSE_i = \sqrt{\left(\frac{1}{N}\right) \sum_{n=1}^N e_i(n)^2}, \quad (16)$$

$$e_i(n) = x_{non-affine,i}(n) - x_{affine,i}(n), i \in \{1, 2, 3\}$$

Table I and Table II list the computed RMSE for several cases (α_0 and α). Examining these two Tables reveals this point that the closer the control input α to α_0 , the lower will be the RMSE. This implies that the number of samples, taken from α_0 in (14), needs to be increased in order to achieve lower error levels.

Table I and Table II express that the RMSE is maximized when α has the longest possible distance from α_0 . For example, for $\alpha_0 = 1$ in (14), both $\alpha = 0.75$ and $\alpha = 1.25$ produce the longest distance around $\alpha_0 = 1$; hence, both RMSE are quite high. Minimum value for the RMSE occurs when $\alpha = \alpha_0$ which is very small.

TABLE I. RMSE FOR $\alpha_0 = 1$

α	RMSE
1.25	$[19.1975 \ 18.9678 \ 19.7166]^T$
1.1	$[7.1676 \ 7.1616 \ 7.1917]^T$
1	$[1.4 \times 10^{-10} \ 1.2 \times 10^{-10} \ 1.3 \times 10^{-10}]^T$
0.9	$[7.1665 \ 7.1604 \ 7.1911]^T$
0.75	$[17.9148 \ 17.8994 \ 17.9764]^T$

TABLE II. RMSE FOR $\alpha_0 = 0.5$

α	RMSE
0.75	[17.9150 17.8996 17.9714] ^T
0.6	[7.1658 7.1595 7.1879] ^T
0.5	[1.7 × 10 ⁻¹⁰ 1.6 × 10 ⁻¹⁰ 1.5 × 10 ⁻¹⁰] ^T
0.4	[7.1660 7.1595 7.1870] ^T
0.25	[17.9160 17.8995 17.9655] ^T

IV. CONCLUSION

The advantage of SSSAM for power electronic converters is that the switching behaviors are considered in modeling. But SSSAM is non-affine and therefore conventional control algorithms cannot be used. In this paper a decomposition procedure is proposed which provides an affine SSSAM for STATCOM. Simulation results of the proposed decomposition procedure with MATLAB show that the resulted affine SSSAM has acceptable modeling error and impressively is applicable to power electronic systems with limit cycle.

TABLE III. LISTS OF SYMBOLS

<i>Symbol</i>	<i>Description</i>
C	Capacity of DC link
L	Inductance of output filter
R	Resistance of output filter
V_c	Voltage of DC link
V_o	STATCOM voltage backside of filter
V_n	STATCOM voltage ahead of filter
$V_{a,b,c}$	STATCOM voltage ahead of transformer
i_a	STATCOM current of phase 'a'
i_b	STATCOM current of phase 'b'
i_c	STATCOM current of phase 'c'
S_a	Switching function of leg 'a'
S_b	Switching function of leg 'b'
S_c	Switching function of leg 'c'
l_{th}	Thevenin inductance of infinite network
r_{th}	Thevenin resistance of infinite network
v_{th}	Thevenin voltage of infinite network
i_{th}	Thevenin current of infinite network
$i_{statcom}$	Output current of STATCOM
i_{load}	Load current

REFERENCES

- [1] P. W. Lehn, M. R. Iravani, 'Experimental evaluation of STATCOM closed loop dynamics', IEEE Transactions on Power Delivery, Vol. 13, No. 4, October 1998
- [2] S. Panda and R. N. Patel, 'Transient Stability Improvement by Optimally Located STATCOMs Employing Genetic Algorithm', International Journal of Energy Technology and Policy, Vol. 5, No. 4, pp. 404-421, 2007
- [3] B. K. Bose, 'An adaptive hysteresis band current control technique of a voltage feed PWM inverter for machine drive system', IEEE Trans. Ind. Electron., 37 (5), pp. 402-406, 1990.
- [4] Chi Kong Tse. 'Complex behavior of switching power converters', CRC Press LLC, pp. 81-82, 2004
- [5] M. Tvakoli Bina. D, C, Hamil. 'Average circuit model for angle-controlled STATCOM', IEE Proc.-Electr. Power Appl., Vol. 152, No. 3, May 2005

- [6] R. D. Middlebrook, and S. Cuk, 'A general unified approach to modeling switching-converter power stages'. Proc. Power Electronics Specialists Conf., 1976, pp. 18-34
- [7] E. A. Walters, 'Automated averaging techniques for power electronic-based systems', Thesis Submitted to Faculty of Purdue University, 1999